

CANNED MOTOR PUMPS

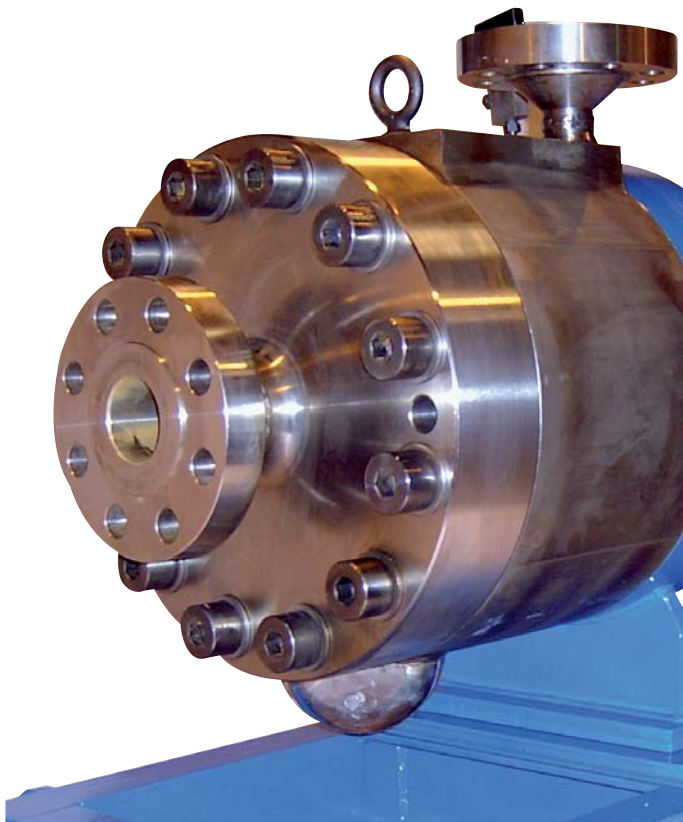

For almost 200 years Hayward Tyler have designed and built **customer-driven solutions** for industries all over the world. In 1965 we launched our first Canned Motor Pump and today there are many thousands of our pumps providing **continuous and reliable service** throughout the chemical, pharmaceutical, petrochemical, nuclear and related process industries.

Canned motors have a wide range of applications such as the primary driver for pumps, mixers and compressors. In all cases the motor components are **shielded from the process fluid** by non-magnetic cans with the stator can providing the primary containment of the process fluid. The outer body of the motor is constructed in compliance with the design pressure of the system in which it is to operate and provides the secondary boundary or double containment feature of the canned motor.

At the heart of a Hayward Tyler canned motor is a **specially engineered squirrel cage induction** electric motor that utilises the latest available motor interior materials to provide **the most robust and reliable rotor/stator** combination possible. For example while conventional motors rely upon class F insulation materials, Hayward Tyler canned motors use, as a minimum, class H materials, which by comparison provide **greatly enhanced operating life**.

The rotor is supported at either end on process lubricated plain bearings, while the **process fluid also acts as a coolant** for the rotor and stator. This design eliminates the need for either ball bearings or a motor fan, which inherently makes canned motors not only considerably quieter but also significantly **more reliable than conventional motors**. The impeller / rotor assembly is dynamically and hydraulically balanced, thus eliminating axial thrust.

Most importantly the close coupled design eliminates the need for a dynamic mechanical seal between the motor and the driven equipment, which is key to meeting the ever more stringent environmental and health & safety standards imposed upon industry today.

Utilising conventional centrifugal pump ends (single stage and multi-stage), both standard models and a variety of specially engineered designs, tailored to meet specific client requirements, can be provided.

www.haywardtyler.com

'C' & CT Range Canned Motor Pumps

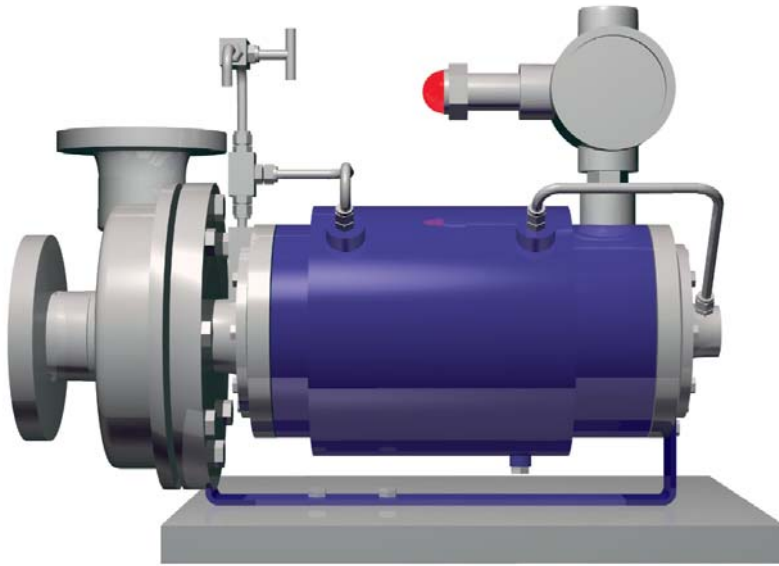

Standard and Optional Features

- Sealless & leakproof
- Compact & quiet
- Easily maintained
- High temp design
- High pressure design
- Explosion-proof design
- Bearing wear detector
- Back flush, reverse or pressurised circulation
- Hardened rotor journals/SiC bearings
- Vertical and submersible designs
- Inducers
- Sensors and monitoring devices
- High pressure leakproof terminal box

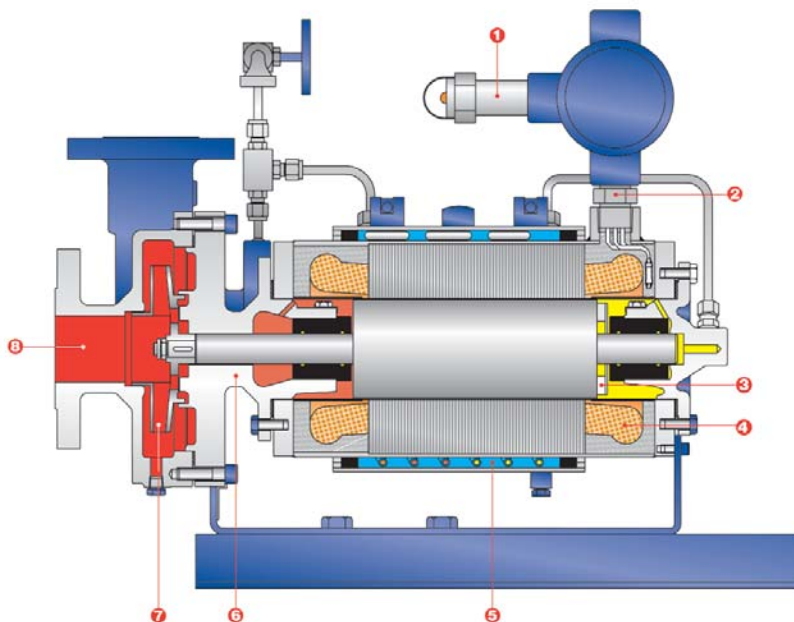

- 1 Rotation Indicator**
– fitted to all standard terminal boxes to ensure correct direction of rotation.
- 2 Double Containment**
– leakproof connector guarantees pump integrity and zero leakage.
- 3 Auxiliary Impeller**
– for high temp 'CT' design (400°C) to circulate fluid around heat exchanger.
- 4 Solid Encapsulation**
– enhanced cooling of H (180°C) insulated motor windings, extending motor life.
- 5 Heat Exchanger**
– to maintain motor cooling flow below 120°C on 'CT' design models.
- 6 Hot Neck** – keeps hot casing end (400°C) away from cool motor end (120°C) in 'CT' design models.
- 7 Impeller** – hydraulically balanced and remote from motor cooling circulation.
- 8 Casing** – flanges to PN16 as standard with other options available.

Specifications and Materials of Construction

Component	C & CT
Pump end	HT standard ¹
Motor (kW)	1.1 to 37
Fluid Temp (°C)	-200 to 400
System Pressure (Barg)	250 max.
Speed (RPM)	2880/1450

Component	C & CT
Can Material	316 L
Journal Bearings	Carbon GR114
Sleeves	Option ²
Thrust Surfaces	Option ³
Insulation Class	H 180 °C

1 Hayward Tyler standard pump end with PN16 flanges.

2 Hard coated journals available.

3 Thrust surfaces for vertical mounted pumps.

Many different options and modifications to these standard specifications are available to suit individual customer requirements.

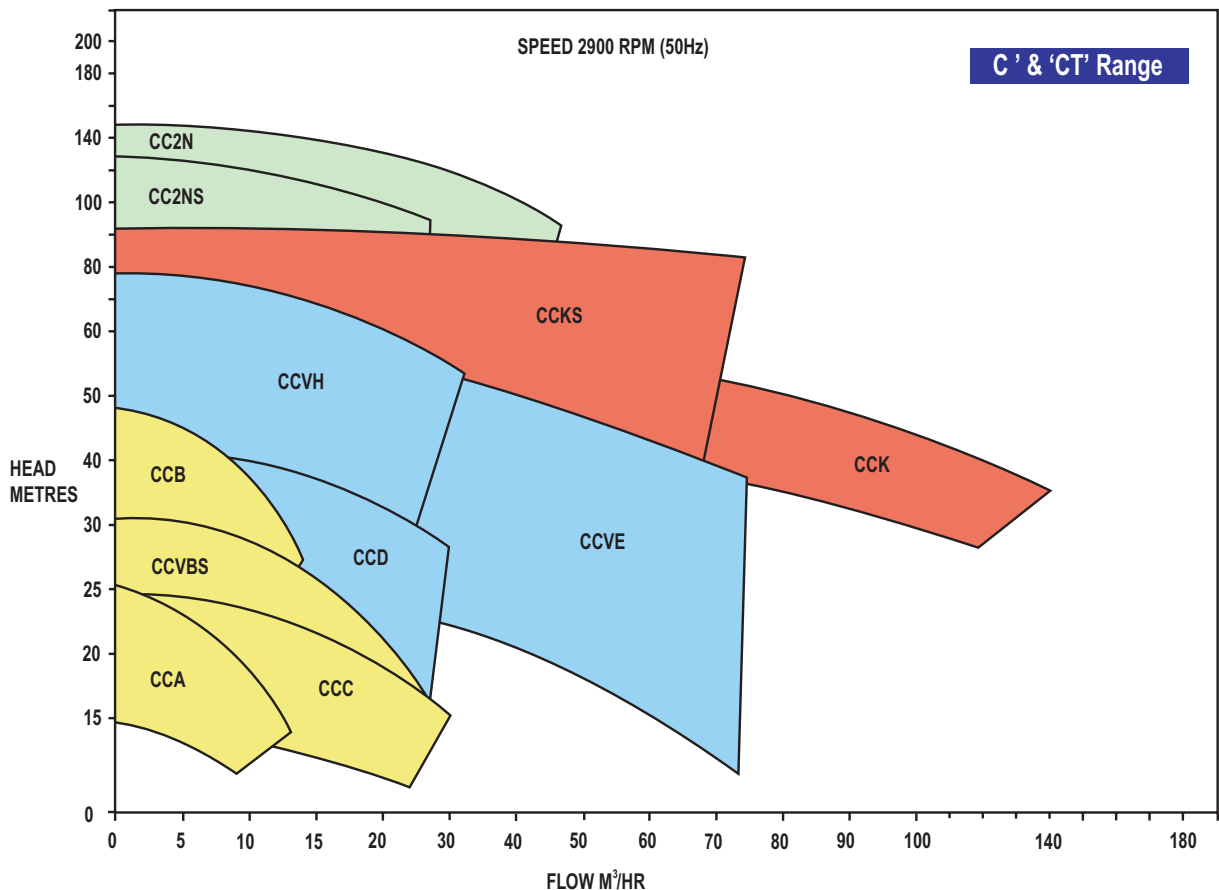



Reduced Installation Costs

As the motor and wet end of a Canned Motor Pump are integral in design, there is no need for a coupling, guard or a heavy duty baseplate, all of which significantly reduces installation costs.

The significant reduction in lifetime cost of ownership that our Canned Motor Pumps offer, in addition to their guaranteed double containment BAT (best available technology) design, backed up by 50 years of applications knowledge and installation experience, makes them first choice for many process pump users.

To find out more about our range of canned motor pumps, please visit our website or talk to one of our first class engineers on +44 (0) 1355 225461.



Services

Our global resource centres provide on going maintenance and support for all our Hayward Tyler products and those of other OEM's.

Our first class engineers offer a comprehensive range of options for pumps and motors, complemented by a vast spares warehouse, ensuring that your business processes are uninterrupted and running at optimum levels at all times.

For more information please visit our website.



info@haywardtyler.com

www.haywardtyler.com

pushing the boundaries of motor technology